

**NOTICE DE SECURITE**

- Conservez cette notice tant que vous utilisez l'appareil.
  - Le montage et l'entretien sont réservés à des personnes qualifiées pouvant intervenir sur des produits devant être reliés manuellement à du courant 230V
  - Avant toute action de montage, coupez l'alimentation électrique
  - Reliez en premier le câble de la mise à la terre
  - La source lumineuse de ce luminaire n'est pas remplaçable ; lorsque la source lumineuse atteint sa fin de vie, le luminaire entier doit être remplacé.
  - En fin de vie, ne pas jeter les luminaires LED.
- Suivez les instructions sur [www.reculum.fr](http://www.reculum.fr)

**SAFETY NOTE**

- Keep this note as long as you use the device.
  - The assembly and the maintenance must be done by qualified people who can intervene on products that must be manually connect to 230V current
  - Before any assembly, cut the power supply
  - First of all connect the ground wire.
  - The light source of this lamp is not replaceable ; when the light source reaches its end of life, the entire lamp must be replaced.
  - Do not throw LED lamps on their end of life.
- Follow the instructions on [www.reculum.fr](http://www.reculum.fr)

**INSTRUCCIONES DE SEGURIDAD**

- Conserve esta reseña mientras utiliza el aparato.
  - El montaje y el mantenimiento son reservados a personas cualificadas que puedan intervenir sobre productos que requieren conexión manual a la corriente 230V
  - Antes de empezar el montaje, corte la corriente eléctrica
  - Conectar primero el cable de tierra
  - La fuente de luz de esta lámpara no es reemplazable ; cuando la fuente de luz llega al final de su vida, toda la lámpara debe ser sustituida.
  - No tire la luminaria LED al final de su vida útil.
- Siga las instrucciones en [www.reculum.fr](http://www.reculum.fr)

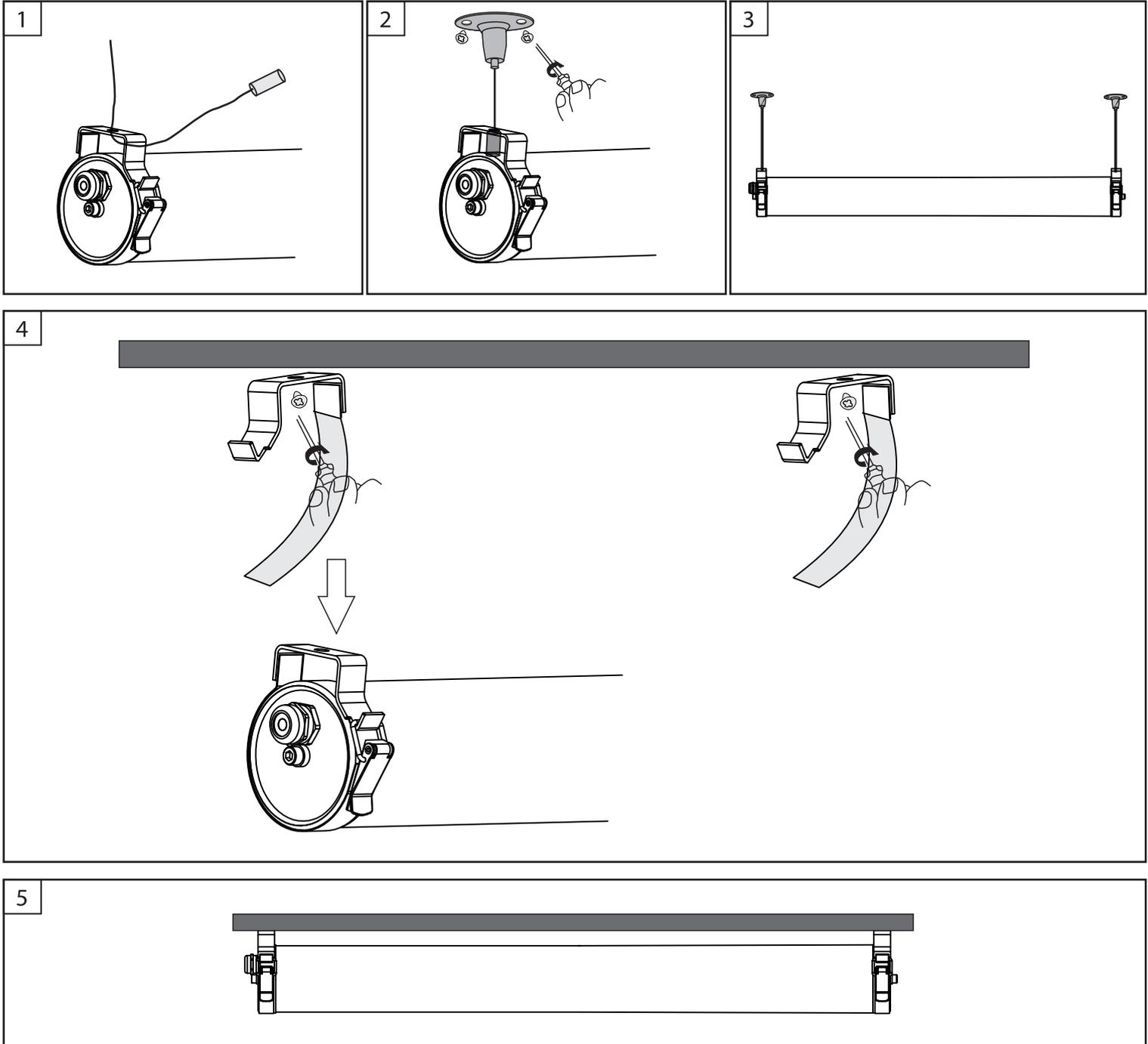

Customers service  
**MIIDEX FRANCE**  
 1 rue Isaac Newton  
 31830 Plaisance Du Touch  
 FRANCE  
[www.miidex.com](http://www.miidex.com)

**AVVISO DI SICUREZZA**

- Conservare questo manuale finché si utilizza il dispositivo.
  - L'installazione e la manutenzione sono riservate a persone qualificate che possono lavorare su prodotti che devono essere collegati manualmente alla corrente a 230V.
  - Prima di qualsiasi azione di montaggio, spegnere l'alimentazione
  - Collegare prima il cavo dalla messa a terra
  - La fonte di luce di questo apparecchio non è sostituibile ; quando la fonte di luce raggiunge la sua fine della vita, l'intero apparecchio deve essere sostituito.
  - Alla fine della vita, non smaltire gli apparecchi a LED.
- Segui le istruzioni su [www.reclum.fr](http://www.reclum.fr)

**SICHERHEITSHINWEIS**

- Bewahren Sie dieses Handbuch so lange auf, wie Sie das Gerät verwenden.
- Installation und Wartung sind qualifizierten Personen vorbehalten, die an Produkten arbeiten können, die manuell an 230 V Strom angeschlossen werden müssen.
- Schalten Sie vor jeder Montage die Stromversorgung aus
- Schließen Sie das Kabel zuerst an die Erdung an
- Die Lichtquelle dieser Leuchte ist nicht austauschbar ; wenn die Lichtquelle das Ende ihrer Lebensdauer erreicht, muss die gesamte Leuchte ausgetauscht werden.
- Entsorgen Sie am Ende des Lebenszyklus keine LED-Leuchten. Folgen Sie den Anweisungen auf [www.reclum.fr](http://www.reclum.fr)

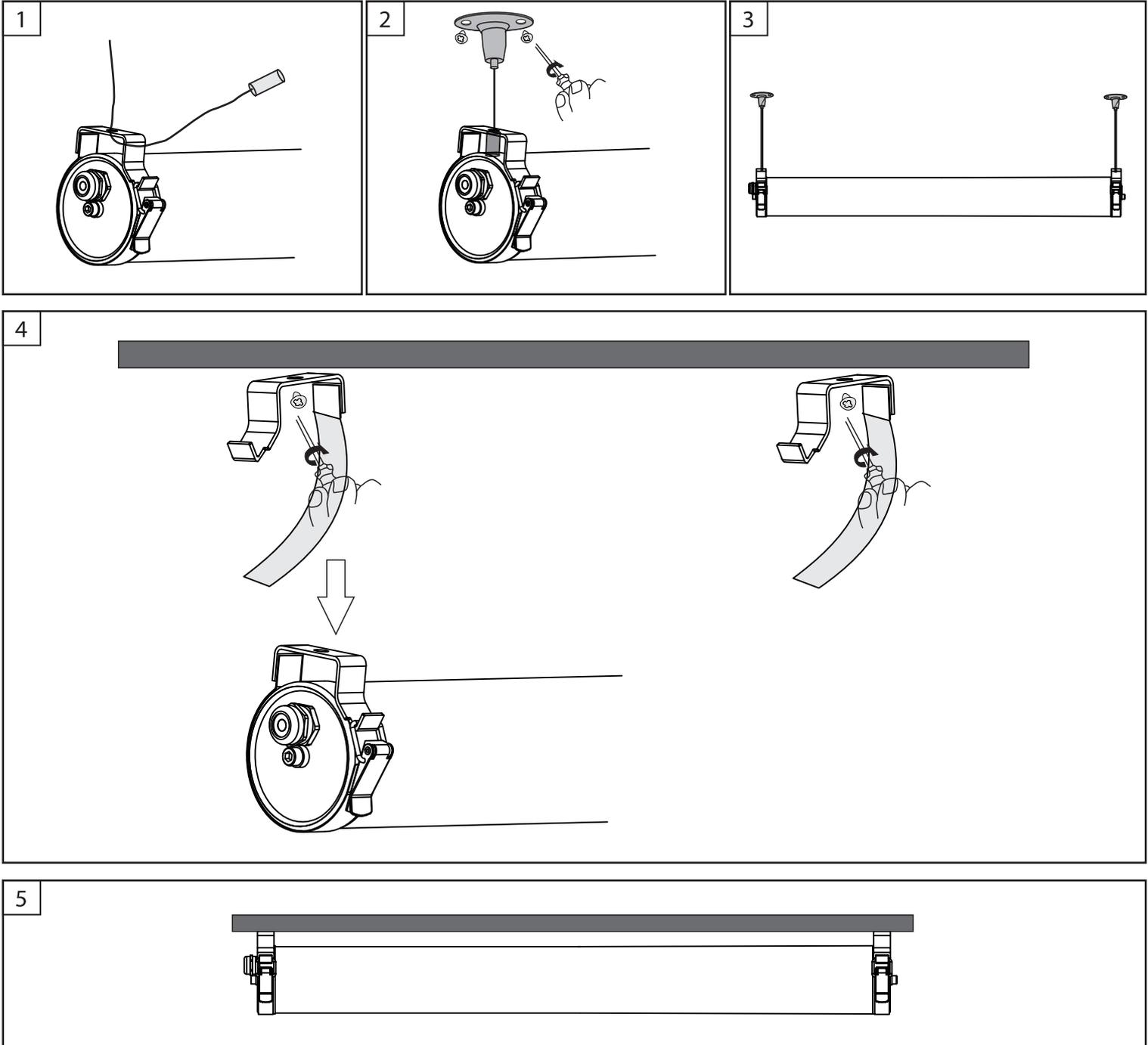

Customers service  
**MIIDEX FRANCE**  
 1 rue Isaac Newton  
 31830 Plaisance Du Touch  
 FRANCE  
[www.miidex.com](http://www.miidex.com)