

NOTICE DE SECURITE

- Conservez cette notice tant que vous utilisez l'appareil.
 - Le montage et l'entretien sont réservés à des personnes qualifiées pouvant intervenir sur des produits devant être reliés manuellement à du courant 230V
 - Avant toute action de montage, coupez l'alimentation électrique
 - La source lumineuse de ce luminaire n'est pas remplaçable ; lorsque la source lumineuse atteint sa fin de vie, le luminaire entier doit être remplacé.
 - En fin de vie, ne pas jeter les luminaires LED.
- Suivez les instructions sur www.reculum.fr

SAFETY NOTE

- Keep this note as long as you use the device.
 - The assembly and the maintenance must be done by qualified people who can intervene on products that must be manually connect to 230V current
 - Before any assembly, cut the power supply
 - The light source of this lamp is not replaceable ; when the light source reaches its end of life, the entire lamp must be replaced.
 - Do not throw LED lamps on their end of life.
- Follow the instructions on www.reculum.fr

INSTRUCCIONES DE SEGURIDAD

- Conserve esta reseña mientras utiliza el aparato.
 - El montaje y el mantenimiento son reservados a personas cualificadas que puedan intervenir sobre productos que requieren conexión manual a la corriente 230V
 - Antes de empezar el montaje, corte la corriente eléctrica
 - La fuente de luz de esta lámpara no es reemplazable ; cuando la fuente de luz llega al final de su vida, toda la lámpara debe ser sustituida.
 - No tire la luminaria LED al final de su vida útil.
- Siga las instrucciones en www.reculum.fr

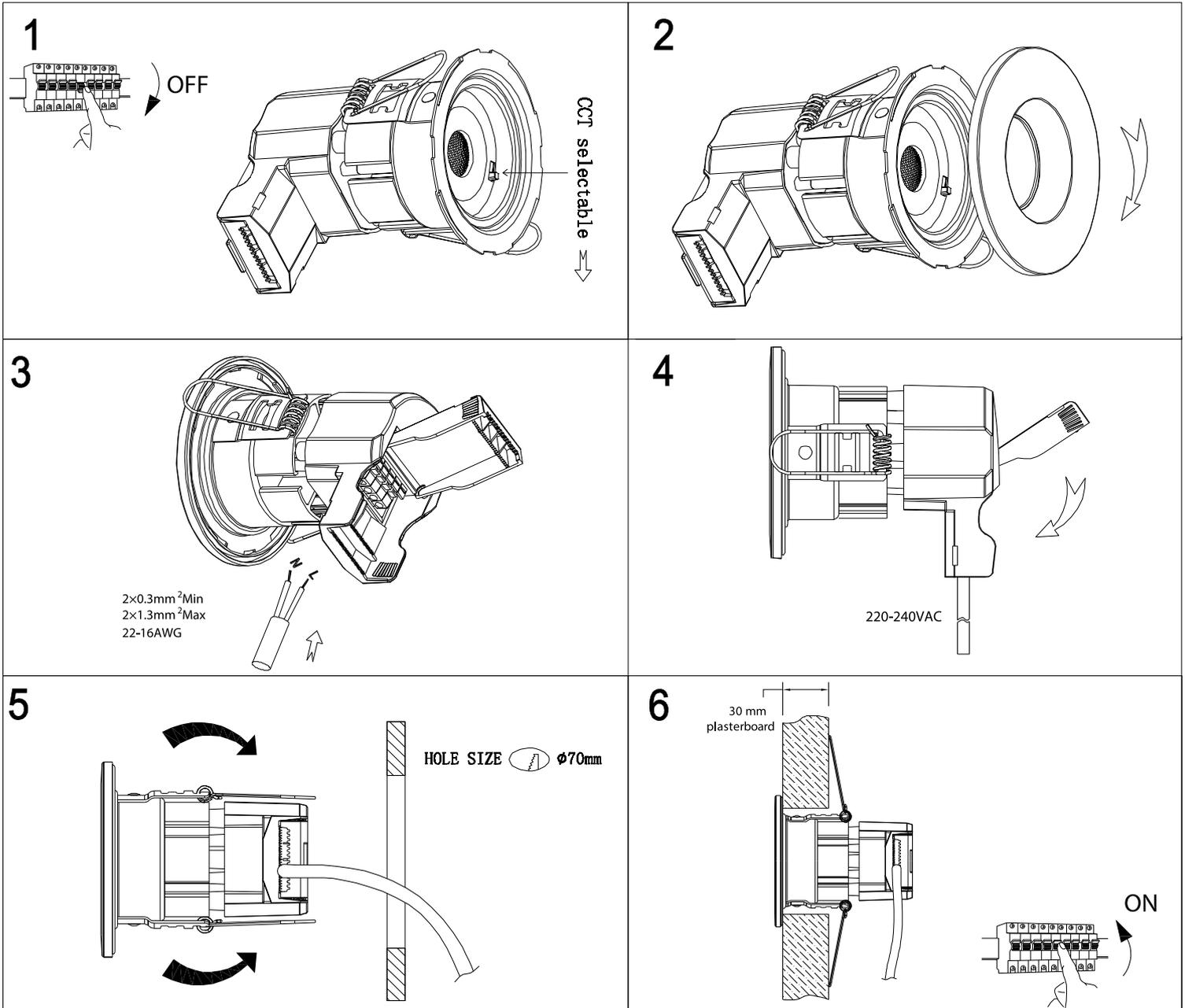

Customers service
MIIDEX FRANCE
 1 rue Isaac Newton
 31830 Plaisance Du Touch
 FRANCE
www.miidex.com

AVVISO DI SICUREZZA

- Conservare questo manuale finché si utilizza il dispositivo.
 - L'installazione e la manutenzione sono riservate a persone qualificate che possono lavorare su prodotti che devono essere collegati manualmente alla corrente a 230V.
 - Prima di qualsiasi azione di montaggio, spegnere l'alimentazione
 - La fonte di luce di questo apparecchio non è sostituibile ; quando la fonte di luce raggiunge la sua fine della vita, l'intero apparecchio deve essere sostituito.
 - Alla fine della vita, non smaltire gli apparecchi a LED.
- Segui le istruzioni su www.recyllum.fr

SICHERHEITSHINWEIS

- Bewahren Sie dieses Handbuch so lange auf, wie Sie das Gerät verwenden.
 - Installation und Wartung sind qualifizierten Personen vorbehalten, die an Produkten arbeiten können, die manuell an 230 V Strom angeschlossen werden müssen.
 - Schalten Sie vor jeder Montage die Stromversorgung aus
 - Die Lichtquelle dieser Leuchte ist nicht austauschbar ; wenn die Lichtquelle das Ende ihrer Lebensdauer erreicht, muss die gesamte Leuchte ausgetauscht werden.
 - Entsorgen Sie am Ende des Lebenszyklus keine LED-Leuchten.
- Folgen Sie den Anweisungen auf www.recyllum.fr

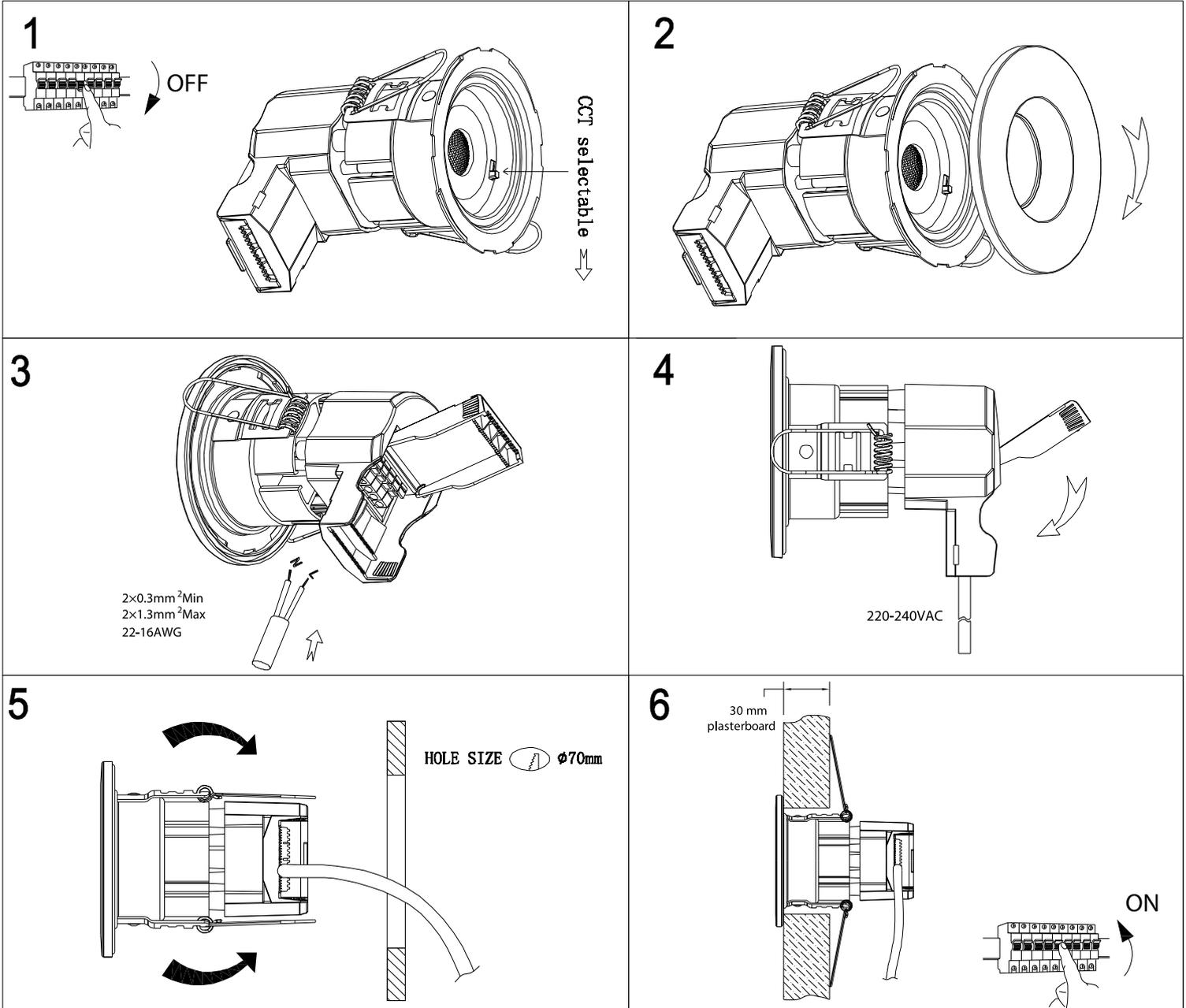

Customers service
MIDEX FRANCE
 1 rue Isaac Newton
 31830 Plaisance Du Touch
 FRANCE
www.midex.com